

**Koyo**

---

**Indice**

**RODAMIENTOS DE BOLAS DE LA SERIE 83000 (INCLUYE 83A000, 83B000, 83C000)**



## Rodamientos de bolas de la serie 83000 (incluye 83A000, 83B000, 83C000)

Los rodamientos de bolas de la serie 83000 de **Koyo** (incluye: 83A000, 83B000, 83C000) son fabricados tomándose como base de diseño, los tipos estándares de los rodamientos rígidos de bolas de 1 ó 2 hileras (series 6000, 6200, 6300, 6900, RLS..., RMS..., 4200, 4300), de los rodamientos de bolas con contacto angular de 1 ó 2 hileras (series 70000, 7200, 7300, 5200, 5300, 3200, 3300) o de rodamientos de bolas axiales (serie 51000, etc.), pero con modificaciones en sus dimensiones principales, biseles, tratamientos térmicos, sellos, etc.

El sistema de designación de esta serie es particular **Koyo** y se inicia con la combinación de números y letras: 83..., 83A..., 83B..., 83C..., como numeración básica seguida de sufijos adicionales (letras y números que informan sobre las especialidades que presentan). En este grupo hemos contenido las series 880000, RW000.

A diferencia de la mayoría de las normas de designación que rigen para los rodamientos, el número básico no guarda relación con las dimensiones principales del rodamiento y sólo representan un número consecutivo de aparición. Aplicaciones comunes: ruedas, tensores, motor fuera de borda, transmisión, etc.

Ejemplos:

83423DB	Rueda delantera -Nissan-	Diseño básico: rodamiento de la serie 7200 (chanfle especial en anillo interno)
83427	Motor fuera de borda-Yamaha-	Diseño básico: rodamiento de la serie 5200 (jaula especial, ranura en anillo externo)
83A174SH2C3	Transmisión -Toyota-	Diseño básico: rodamiento de la serie 6300 (biseles mayores, ranura en anillo ext., tratam. térmico en aro interno)

Los cambios más recurrentes en los diseños de rodamientos básicos son: el aro externo extendido, más ancho, con perfil especial, con pasador, con ranura, etc. En el aro int. más grueso, radio de chanfle distinto, sello metálico, sello reforzado.

▶ RODAMIENTOS AUTOMOTRICES

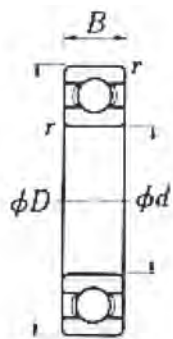

(abierto)

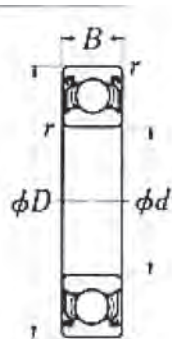

(obturados - sellados)



(con ranura - anillo elástico)

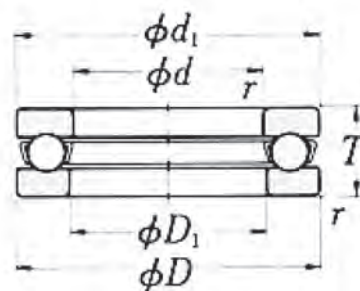

(simple efecto)

Rodamientos rígidos de bolas

Rodamientos axiales de bolas

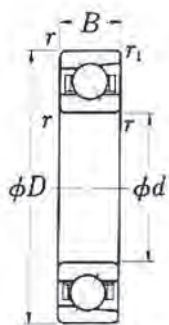

(una hilera)

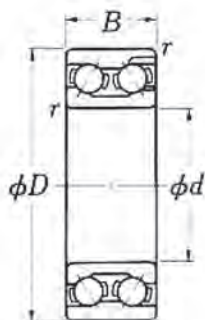



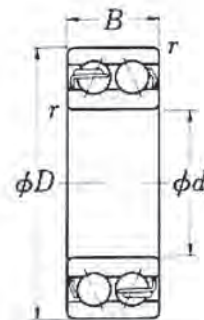











(doble hilera, serie 32...,33...)















(doble hilera, serie 52...,53...)











Rodamientos de bolas con contacto angular

Rodamientos de bolas (rígidos, contacto angular, etc.) -series 83XXX, 83A..., 83B..., 83C... 88XXX										
Designación	Foto	Número de parte (O.E.M)	Fabricante	Aplicación	Dimensiones principales (unidad:mm)					Observación
					d diám.a.i	D Diám.a.e	B ancho ttl. o mayor	Bi ancho aro i.	Be ancho aro e.	
Serie 83000										
83044		195507MI	MASSEY FERGUSON	TRACTOR	55.00	100.00	21.00	21.00	21.00	Descontinuado
83044CS		195507MI	MASSEY FERGUSON	TRACTOR	55.00	100.00	21.00	21.00	21.00	Descontinuado
83064C3		9-00090-164-0	ISUZU	N/D	16.00	40.00	12.00	12.00	12.00	Descontinuado
83085		N/D	FORD	Caja de cambio	55.00	100.00	21.00	21.00	21.00	6211 con jgo.int.esp.y bolas + grandes.
83111C3		76181-30340-71A	KOMATSU	Mástil-MONTACARGA	40.00	100.00	30.00	23.00	30.00	Venta exclusiva
83111C3		N/D	TOYOTA	Mástil-MONTACARGA	40.00	100.00	30.00	23.00	30.00	Venta exclusiva
83179YRE2C3		1-09800-087(8)	ISUZU	N/D	60.00	110.00	22.00	22.00	22.00	•
83210BC3		N/D	DANA-Spicer	Transmisión manual	40.00	90.00	20.00	20.00	20.00	Base:6308N. sin anillo (a.e) y abierto.
83270		81804635	NEW HOLLAND	TRACTOR	65.00	100.00	18.00	18.00	18.00	Basado en 6013.
83270		N/D	FORD	TRACTOR	65.00	100.00	18.00	18.00	18.00	Basado en 6013.
83294C4		43215-18000	NISSAN	RUEDA TRAS.	32.00	62.00	16.00	16.00	16.00	•
83294C4		43210-21000	NISSAN	RUEDA TRAS.	32.00	62.00	16.00	16.00	16.00	•
83299SH2-9RTC4		93306-20438	YAMAHA (YZ80)	Cigüeñal (D) motocicleta	20.00	47.00	14.00	14.00	14.00	•
83357A-9C4		09269-25013	SUZUKI	Cigüeñal motocicleta	25.00	62.00	•	17.00	•	•
83404-9C3		93306-20604	YAMAHA	Cigüeñal motor fuera borda	30.00	62.00	16.00	16.00	16.00	Descontinuado
83406-9TC4		93306-30549	YAMAHA	Cigüeñal motocicleta	25.00	62.00	17.00	17.00	17.00	Basado en 6305N-9
83406E1-9C3		93306-30531	YAMAHA	Cigüeñal motor comb. int.	25.00	62.00	17.00	17.00	17.00	Descontinuado
83427		93305-20502	YAMAHA	Transmisión motor comb. int.	25.00	52.00	20.60	20.60	16.60	•
83447A-9C3		09269-30006	SUZUKI	Motor fuera /borda	30.00	72.00	19.00	19.00	19.00	Con buje para lubricación
83464A-9TC3		93306-30510	YAMAHA	Cigüeñal motor comb. int	25.00	62.00	17.00	17.00	17.00	•
83464A1-9TC4		N/D	YAMAHA	Cigüeñal (I) motor c.int	25.00	62.00	17.00	17.00	17.00	•





Rodamientos de bolas (rígidos, contacto angular, etc.) -series 83XXX, 83A..., 83B..., 83C... 88XXX											
Designación	Foto	Número de parte (O.E.M)	Fabricante	Aplicación	Dimensiones principales (unidad:mm)					Observación	
					d diám.a.i	D Diám.a.e	B ancho ttl. o mayor	Bi ancho aro i.	Be ancho aro e.		
83464RSH2-9TCS30		09262-25099	SUZUKI (RGV. Wolf)	Cigüeñal motocicleta	25.00	62.00	18.00	18.00	18.00	•	
83477CS23		9-00090-655-0	ISUZU	TRANSMISIÓN	32.00	75.00	20.00	20.00	20.00	Anillo-ranura aro ext. Escote de relleno en aros	
83490		9881-60109A	HINO	N/D	60.00	130.00	31.00	31.00	31.00	Descontinuado	
83516-9TC3		353-001118-0	TOHATU	Bomba de agua	30.00	72.00	19.00	19.00	19.00	Pasador en aro externo	
83516CSH2-9TC4		09262-30055	SUZUKI	N/D	30.00	72.00	19.00	19.00	19.00	Pasador en aro externo	
83522PC3		N/D	KOMATSU	Mastil-Montacarga	40.00	109.70	32.00	23.00	32.00	Rodam. base 63082RK	
83522PC3		N/D	TOYOTA	Mastil-Montacarga	40.00	109.70	32.00	23.00	32.00	Rodam. base 63082RK	
83526D-9C3		09269-35006	SUZUKI	N/D	35.00	80.00	21.00	21.00	21.00	•	
83543KC3		N/D	KOMATSU	MONTACARGA	35.00	94.50	28.00	21.00	28.00	Venta exclusiva	
83544KC3		N/D	KOMATSU	MONTACARGA	35.00	114.50	28.00	21.00	28.00	Aro externo más ancho. grueso. obturado.	
83546-9C3		09262-25030	SUZUKI (GT)	Cigüeñal motor c.i.	25.00	52.00	15.00	15.00	15.00	•	
83546SH2C3		93306-20575	YAMAHA	Transmisión/ Motocicleta	25.00	52.00	15.00	15.00	15.00	Descontinuado	
83549C3		C5NN-N779-B	FORD	EJE PILOTO	36.51	68.00	15.00	15.00	15.00	•	
83553ASH2-9RCS20		09262-35001	SUZUKI	Cigüeñal de motor c.i.	35.00	72.00	17.00	17.00	17.00	Descontinuado	
83580AC3		09262-25050	SUZUKI	Transmisión/ Motocicleta	25.00	62.00	17.00	17.00	17.00	•	
83580ASH2CS23		09262-25105	SUZUKI	Transmisión/ Motocicleta	25.00	62.00	17.00	17.00	17.00	•	
83580C-9CS30		09262-25097	SUZUKI	Cigüeñal /Motocicleta	25.00	62.00	17.00	17.00	17.00	•	
83624C3		N/D	CLARK	MONTACARGA	45.00	100.00	21.00	21.00	21.00	Ranura. anillo en aro ext.	
83676+CAP		1494152 MI	MASSEY FERGUSON	N/D	61.91	110.00	61.90	61.90	22.00	Descontinuado	





Rodamientos de bolas (rígidos, contacto angular, etc.) -series 83XXX, 83A..., 83B..., 83C... 88XXX										
Designación	Foto	Número de parte (O.E.M)	Fabricante	Aplicación	Dimensiones principales (unidad:mm)					Observación
					d diám.a.i	D Diám.a.e	B ancho ttl. o mayor	Bi ancho aro i.	Be ancho aro e.	
83746ASH4-9TC3		93306-206-U3	YAMAHA	Cigüeñal/Motor fuera borda	30.00	66.00	•	16.00	•	Venta exclusiva
83763-1SH2C4		N/D	DANA Spicer	TRANSM.MANUAL	40.00	90.00	23.00	23.00	23.00	Descontinuado
83763-1SH2C4		N/D	FORD	TRANSM.MANUAL	40.00	90.00	23.00	23.00	23.00	Descontinuado
83765C3		MD800764	MITSUBISHI	N/D	42.00	85.00	•	19.00	•	Descontinuado
83805C3		949100-1610	NIPPON DENSO	Sist.aire/acondicionado	12.50	32.00	10.00	10.00	10.00	Obturado. Chanfle r=1.0 mm
83805FC2		949100-1610	NIPPON DENSO	Sist.aire/acondicionado	12.50	32.00	10.00	10.00	10.00	Descontinuado
83913-9TC4		93306-30615	YAMAHA	Cigüeñal motor c. int. (motocicleta, motor a popa)	30.00	72.00	19.00	19.00	19.00	Rodamiento abierto. Chanfle: 1.1. 2 mm
83943CSH2C3		09262-22017	SUZUKI	Transmisión/ Motocicleta	22.00	56.00	•	16.00	•	Tratamiento térmico en aro int.
83993SH2CS6		92045-035	KAWASAKI	Transmisión / Motocicleta	25.00	52.00	•	20.60	•	•
Serie 83A000										
83A066PBSCS59		59117-1200	NISSAN	MONTACARGA	45.00	115.00	31.50	25.00	31.50	Aro externo más ancho. grueso.
83A066PBSCS59		912362	JEEP WILLY	EJE DE TOMA	45.00	115.00	31.50	25.00	31.50	Aro externo más ancho. grueso.
83A070SH4CS26		93304-205U0	YAMAHA	MOT.FUERA/BORDA	25.00	57.00	18.00	18.00	18.00	Rodamiento rígido -2 hileras. pasador en a.e.
83A093-9TC4		93306-20627	YAMAHA	Cigüeñal /Motocicleta	30.00	62.00	16.00	16.00	16.00	Rodam. abierto (radio a.i =2.5mm)
83A105BCS17		09262-14001	DAEWOO	SUSPENSIÓN	14.05	42.00	16.00	16.00	11.00	Rodamiento abierto
83A105BCS17		N/D	OPEL	SUSPENSIÓN	14.05	42.00	16.00	16.00	11.00	Rodamiento abierto
83A105BCS17		90105091	GM	N/D	14.05	42.00	16.00	16.00	11.00	Rodamiento abierto
83A167NBC3		3ED7141210	KOMATSU	MONTACARGA	55.00	139.40	45.00	29.00	45.00	Obturado. con aro ext. más ancho.
83A170C4		5-09801-001-0	ISUZU	PIÑÓN FRONTAL	16.00	40.00	12.00	12.00	12.00	Chanfles r=1.0mm
83A174ASH2C3		90363-25029	TOYOTA	TRANSMISIÓN	25.00	62.00	17.00	17.00	17.00	Ranura en aro externo

Rodamientos de bolas (rígidos, contacto angular, etc.) -series 83XXX, 83A..., 83B..., 83C... 88XXX										
Designación	Foto	Número de parte (O.E.M)	Fabricante	Aplicación	Dimensiones principales (unidad:mm)					Observación
					d diám.a.i	D Diám.a.e	B ancho ttl. o mayor	Bi ancho aro i.	Be ancho aro e.	
83A209D-9TC3		93306-306U2	YAMAHA	Cigüeñal/Motor fuera borda	30.00	72.00	19.00	19.00	19.00	Pasador en aro externo
83A263SH4-9TC3		93306-206U5	YAMAHA	Cigüeñal/Motor fuera borda	32.00	66.00	16.00	16.00	16.00	Chanfle= 1.5 mm ext.
83A367CPT4SH2-9C3		09262-30048	SUZUKI	MOTOCICLETA	30.00	72.00	19.00	19.00	19.00	Ranura, pasador en aro externo
83A400C3		90363-32006	TOYOTA	Caja de transferencia	32.00	75.00	20.00	20.00	20.00	Rodam.básico 63/32. Ranura aro ext.
83A460CCS45		8-94220-590	ISUZU	Caja de transferencia	25.00	52.00	23.60	23.60	23.60	Antes 83A460ACS21. Contacto ang. de 2 hileras, sin ranura aro ext.
83A504SH2C3		90363-20075	TOYOTA	TRANSMISIÓN	20.00	57.15	17.46	17.46	17.46	Chanfle a.e.=2.0mm, Chanfle a.i.=0.4mm
83A551BCS45		8536-1020	MAZDA	AIRE ACOND.	40.00	62.00	24.00	24.00	24.00	Rodam. bolas contacto ang. 2 hil, chanfles =1.2mm
83A693CS30		N/D	SANDEN	Aire acondicionado	30.00	47.00	18.00	18.00	18.00	Sello en ambos lados. (Rodamiento base 6906 2RU)
83A693CS30		N/D	DAIHATSU	Aire acondicionado	30.00	47.00	18.00	18.00	18.00	Sello en ambos lados. (Rodamiento base 6906 2RU)
83A693CS30		N/D	SUZUKI	Aire acondicionado	30.00	47.00	18.00	18.00	18.00	Sello en ambos lados. (Rodamiento base 6906 2RU)
83A694CS30		85430020	SANDEN	Sistema Aire acond.	35.00	55.00	20.00	20.00	20.00	Cambio a DAC35552RD3XS1CS33
83A733C3		90363-19004	TOYOTA	DIFERENCIAL	19.00	33.00	7.00	7.00	7.00	Rodam. base 6804
83A735		93306-36401	YAMAHA	Transmisión/ Motocicleta	28.00	68.00	18.00	12.00	18.00	Ranura, anillo y pasador en aro ext.
83A825FSH2-9CS23		93306-306-V2	YAMAHA	Motor fuera /borda	30.00	72.00	21.50	19.00	21.50	Aro ext. Extendido ranura, pasador.

Rodamientos de bolas (rígidos, contacto angular, etc.) -series 83XXX, 83A..., 83B..., 83C... 88XXX										
Designación	Foto	Número de parte (O.E.M)	Fabricante	Aplicación	Dimensiones principales (unidad:mm)					Observación
					d diám.a.i	D Diám.a.e	B ancho ttl. o mayor	Bi ancho aro i.	Be ancho aro e.	
83A831GC5		90369-36001	TOYOTA	J-. Homocinética	36.20	67.00	23.00	23.00	23.00	Placa metálica (ambos lados)
83A831GCS53		90363-36001	TOYOTA	RUEDAS	36.20	67.00	23.00	23.00	23.00	Placa metálica y sello
83A831GCS53		27831-63B00	SUZUKI	RUEDAS	36.20	67.00	23.00	23.00	23.00	Placa metálica y sello
83A831SC5		N/D	SUZUKI (Baleno)	Rodam. central (Cardán)	36.20	67.00	18.40	18.40	18.40	Rodamiento obturado
83A831UCS29		N/D	TOYOTA	DRIVE SHAFT	36.20	67.00	23.00	23.00	23.00	•
83A839AVCS62		9139873-01	KOMATSU	Montacarga	60.00	126.00	31.00	31.00	22.00	Basado en M6212ZZX
83A843SH4-9TC4		09262-30065	SUZUKI	Cigüeñal/Motor fuera borda	30.00	72.00	23.00	19.00	23.00	Descontinuado
83A844ASH2-9TC4		09262-35049	SUZUKI	Cigüeñal/Motor fuera borda	35.00	72.00	17.00	17.00	17.00	Pasador en aro externo
83A898C4		90363-35020	TOYOTA	CAJA TRANSFER.	35.20	80.00	21.00	21.00	21.00	Ranura y anillo en aro ext.
83A910BC3		MB293314	MITSUBISHI	Rodam. central (Cardán)	40.00	72.00	18.00	18.00	17.00	Rodamiento abierto
83A915SH2-9TC4		93306-20562	YAMAHA	Cigüeñal /Motocicleta	25.00	55.00	15.00	15.00	15.00	Chanfles=1.5mm, aro externo grueso.
83A916CSH2-9TC4		93306-20577	YAMAHA	Cigüeñal Izq-Med / Motoc.	25.00	55.00	15.00	15.00	15.00	Aro externo grueso, con pasador (r=1.5mm)
83A941ASH2C3		90363-45010	TOYOTA	TRANSMISIÓN	45.00	100.00	28.00	28.00	28.00	Obturado. Ranura en aro ext.
83A947ASH2-9TCS37		N/D	YAMAHA	Cigüeñal/Motor fuera borda	30.00	72.00	19.00	19.00	19.00	Rodam. abierto Ranura, pasador en aro ext.
83A947ASH2-9TCS37		91004-657-0040	HONDA	Cigüeñal/Motor fuera borda	30.00	72.00	19.00	19.00	19.00	Rodam. abierto Ranura, pasador en aro ext.
83A983CCS5		MB532489	MITSUBISHI	SIST. DIRECCIÓN	17.00	35.00	10.00	10.00	10.00	Placa metálica (1 lado) aro interno grueso.



Rodamientos de bolas (rígidos, contacto angular, etc.) -series 83XXX, 83A..., 83B..., 83C... 88XXX										
Designación	Foto	Número de parte (O.E.M)	Fabricante	Aplicación	Dimensiones principales (unidad:mm)					Observación
					d diám.a.i	D Diám.a.e	B ancho tti. o mayor	Bi ancho aro i.	Be ancho aro e.	
Serie 83B000										
83B051DSH2-9TCS37		93306-20578	YAMAHA	Cigüeñal/ Motocicleta	25.00	55.00	•	15.00	•	Venta exclusiva
83B139SH2C3		93306-20217	YAMAHA	Cigüeñal/ Motocicleta	22.00	50.00	20.60	20.60	20.60	Descontinuado
83B166		AR26845	JOHN DEERE	TRACTOR	65.00	100.00	20.64	18.00	18.00	Placa-tapa metálica para lubricación
83B169ACS63		90369-36008	TOYOTA	DIFERENCIAL	36.20	67.00	•	29.00	•	•
83B207-9CD3		93303-30601	YAMAHA	Motor fuera/borda	32.00	72.00	•	30.20	•	Venta exclusiva
83B216CD3		46AX541	MACK (camión)	Bomba de agua	20.00	52.00	•	25.40	25.40	•
83B218UJ4CM		N/D	BOSCH	ALTERNADOR	17.00	52.00	17.00	17.00	17.00	Obturado
83B231DCS29		90363-41002	TOYOTA	Eje de tracción	41.20	72.00	•	23.00	•	Nuevo # 83B231DCS19
83B247SH2C3		93306-20576	YAMAHA	Motocicleta	25.00	52.00	15.00	15.00	15.00	Descontinuado
83B285SH2C3		93306-637	YAMAHA	Transmisión / Motocicleta	22.00	56.00	16.00	16.00	16.00	Ranura, pasador en aro ext..
83B332		JD8676	JOHN DEERE	TRACTOR	88.90	127.00	19.05	19.05	19.05	Rodamiento abierto
83B333A-9C3		93306-30550	YAMAHA	Transmisión/ Motocicleta	25.00	62.00	17.00	17.00	17.00	Descontinuado
83B437ABS		37B9AA2111	KOMATSU	MONTACARGA	35.00	107.80	•	31.00	•	•
83B569AASH2-9TCS39		91002-KV3-831	HONDA	MOTOCICLETA	28.00	68.00	•	17.00	•	•
83B572 SH2C3		N/D	EATON	Transmisión(eje salida)	63.50	125.00	24.00	24.00	24.00	Descontinuado
83B607ACS8		AA21480	JOHN DEERE	Rueda de plantadora	16.03	45.23	18.67	18.67	15.49	Descontinuado
83B673		91003-MN5-003	HONDA	Transmisión/ Motocicleta	22.00	56.00	•	16.00	•	•
83B700A		91004-KW3-004	HONDA	Transmisión/ Motocicleta	22.00	50.00	•	14.00	•	•
83B716-9RC3		93306-304U0	YAMAHA	MOT.FUERA /BORDA	20.00	57.00	•	15.00	•	Descontinuado
83B717-9RC3		93306-205U2	YAMAHA	MOT.FUERA/BORDA	25.00	57.00	•	15.00	•	Descontinuado
83B727-9C3		93306-307-U1	YAMAHA	MOT.FUERA/BORDA	35.00	80.00	•	21.00	•	Descontinuado

Rodamientos de bolas (rígidos, contacto angular, etc.) -series 83XXX, 83A..., 83B..., 83C... 88XXX										
Designación	Foto	Número de parte (O.E.M)	Fabricante	Aplicación	Dimensiones principales (unidad:mm)					Observación
					d diám.a.i	D Diám.a.e	B ancho ttl. o mayor	Bi ancho aro i.	Be ancho aro e.	
83B729-9C3		93306-307-U3PP00	SANSHIN	Cigüeñal/Motor c. int.	35.00	72.00	•	17.00	•	Descontinuado
83B729-9TC3		93306-207U2	YAMAHA	Cigüeñal/Motor fuera borda	35.00	72.00	17.00	17.00	17.00	Venta exclusiva
83B745CSH4-9TC3		93306-206U7	YAMAHA	Cigüeñal/Motor fuera borda	30.00	66.00	•	16.00	•	Venta exclusiva
83B763BSH2C3		N/D	Taxi-Carbodies(Ing.) Eje GKN	Eje trasero/rueda	35.00	80.00	30.00	30.00	27.00	O-ring en a.e. Aro int. extendido 1 lado
83B889CS10		N/D	N/D	SIST. DIRECCIÓN	18.00	55.00	18.00	18.00	•	Descontinuado
Serie 83C000										
83C032SH2-9TCS37		09262-30068	SUZUKI	Cigüeñal/Motor fuera borda	30.00	72.00	•	19.00	•	•
83C034C3		N/D	TOYOTA.Lucida	Amort. hidráulica	90.00	117.00	15.00	15.00	15.00	Descontinuado
83C062DSH2		5566507	EATON	Transmisión/eje ent.	90.00	140.00	24.00	24.00	24.00	Basado 6018NR
83C111CS31		N/D	TOYOTA	STEERING GEAR	18.72	28.00	7.00	7.00	7.00	•
83C137ESH2-9TCS39		91003-KV3-951	HONDA	MOTOCICLETA	28.00	68.00	•	18.80	•	•
83C259BC3		N/D	FORD-Contour	Col.dirección (eje entrada)	20.66	38.61	6.80	6.80	6.80	Descontinuado
83C288C2		341450	DUNLOP	SUSPENSIÓN	14.00	42.00	16.00	16.00	11.00	Rodamiento obturado
83C399AC3		1344566	SUMITOMO	N/D	35.00	91.80	31.00	20.00	31.00	•
83C507C3		9249323-01	SUMITOMO	MONTACARGA	40.00	111.10	32.36	21.65	32.36	•
Serie 88 00 00										
881072RR4		N/D	(Marca HIC)	RUEDA TRASERA	35.00	72.00	25.00	25.00	17.00	Rodamiento obturado
881282RSE6CS		N/D	(Marca HIC)	RUEDA TRASERA	38.89	80.00	27.50	27.50	21.00	Descontinuado
881282RSE6CS+R		N/D	(Marca HIC)	RUEDA TRASERA	38.89	80.00	27.50	27.50	21.00	Descontinuado
8MTH7025		N/D	CHEVROLET	RUEDA	40.00	90.00	20.00	20.00	20.00	Base 6308N sin anillo Ranura en a. ext.
Serie RW200										
RW207HH		N/D	(Marca HIC)	N/D	35.00	72.00	•	21.46	21.43	Descontinuado
RW207HHC3+R		N/D	(Marca HIC)	N/D	35.00	72.00	•	21.46	21.43	Descontinuado
RW207HHC3+R		N/D	(Marca HIC)	N/D	35.00	72.00	•	21.46	21.43	Descontinuado
RW207HHC3+R1		N/D	(Marca HIC)	N/D	35.00	72.00	•	21.46	21.43	•

► RODAMIENTOS AUTOMOTRICES

SERIE 83000

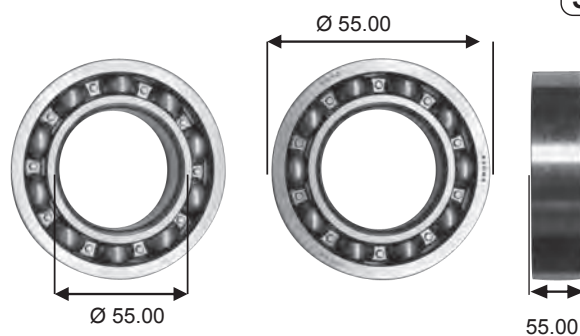

83085

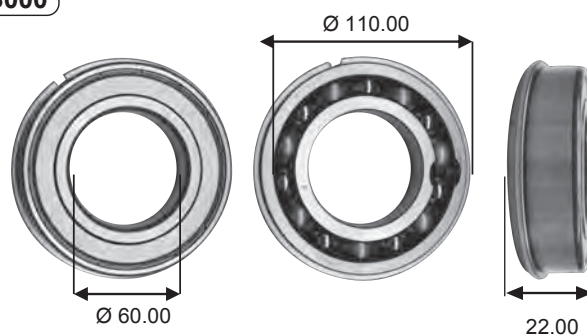

83179YRE2C3

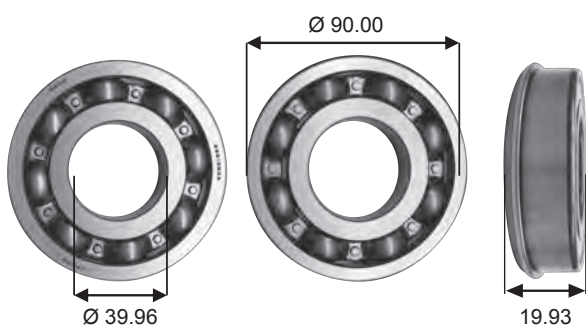

83210BC3

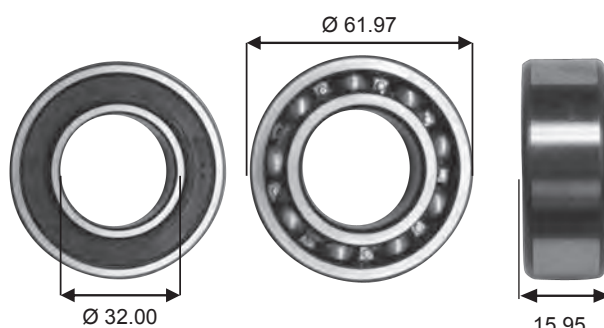

83294C4

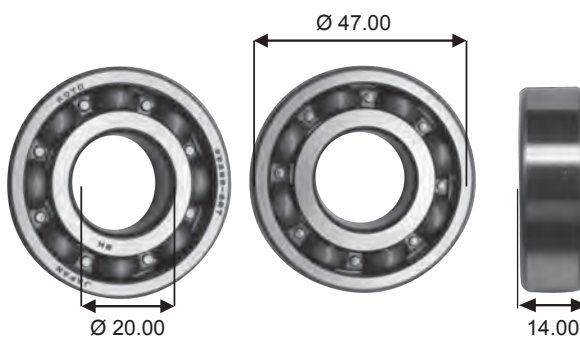

83299SH2 - 9RTC4

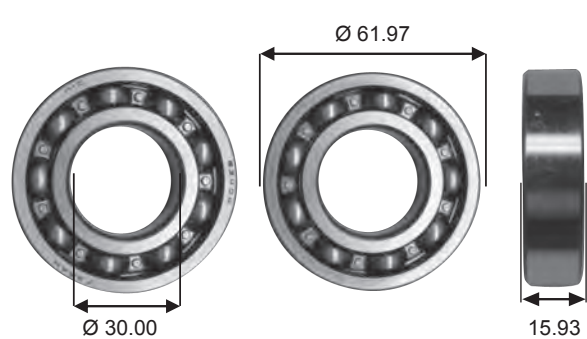

83404 - 9C3

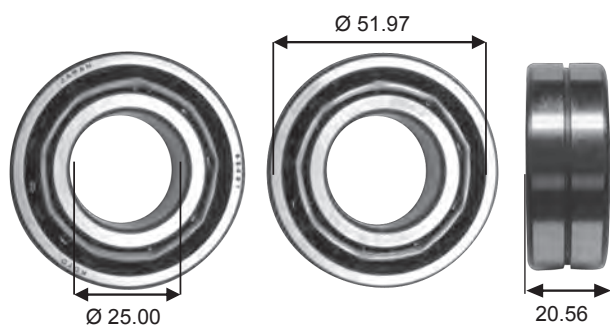

83427

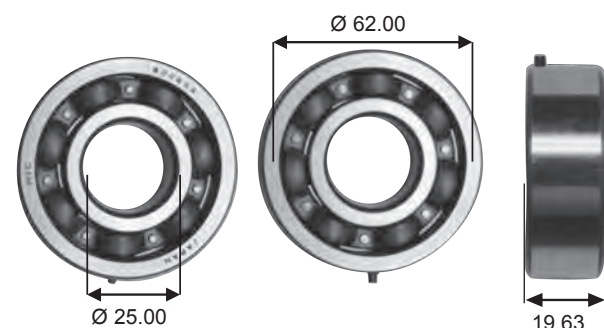

83464A - 9TC3

▶ RODAMIENTOS AUTOMOTRICES

SERIE 83000

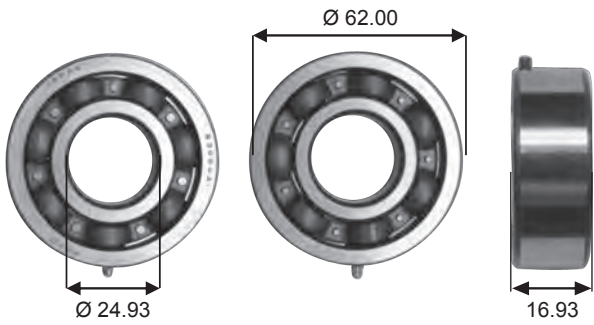

83464A1 - 9TC4

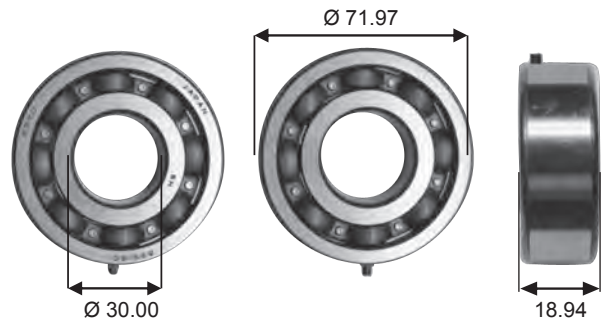

83516CSH2 - 9TC4

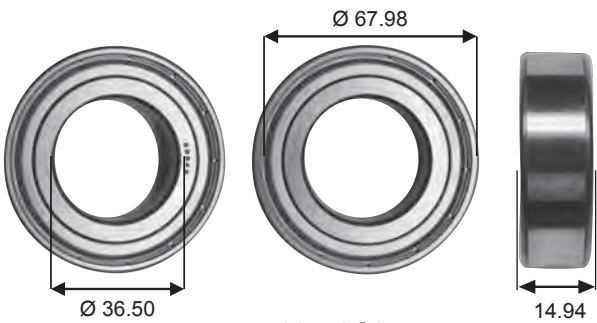

83549C3

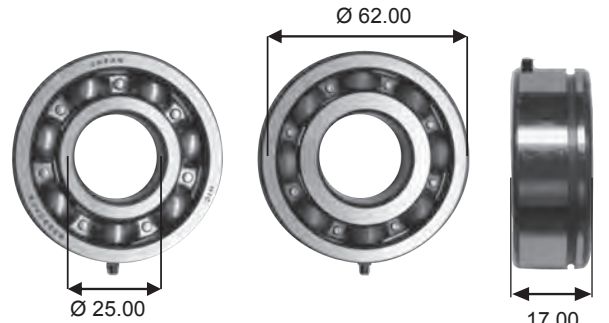

83580AC3

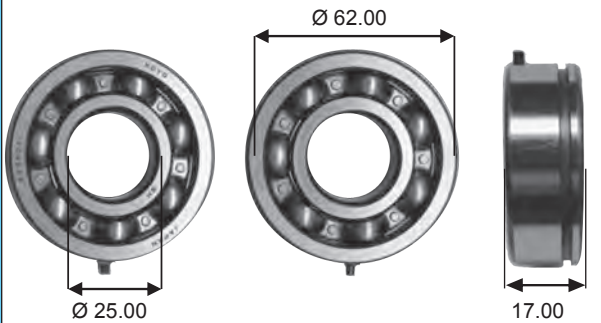

83580ASH2CS23

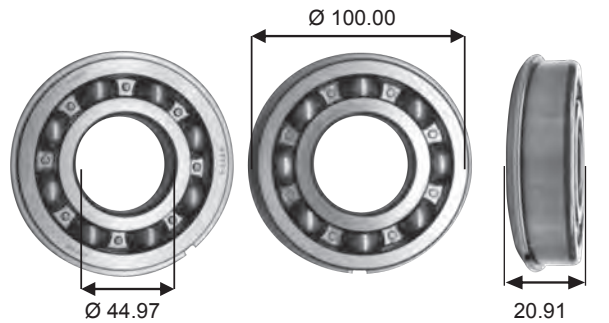

83624C3

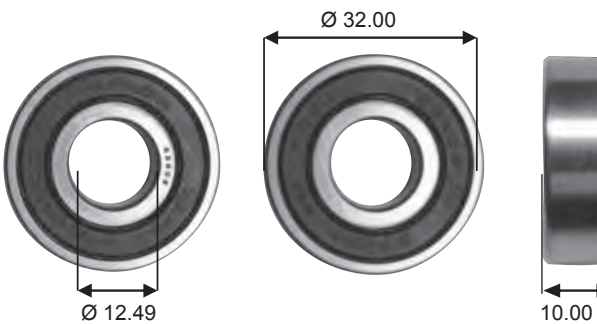

83805C3

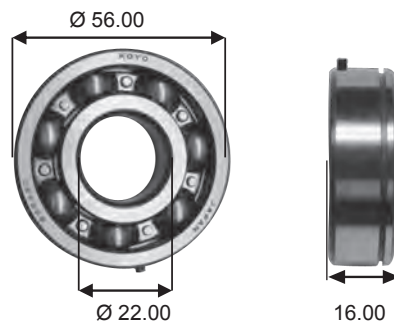

83943CSH2C3



► RODAMIENTOS AUTOMOTRICES

SERIE 83A000

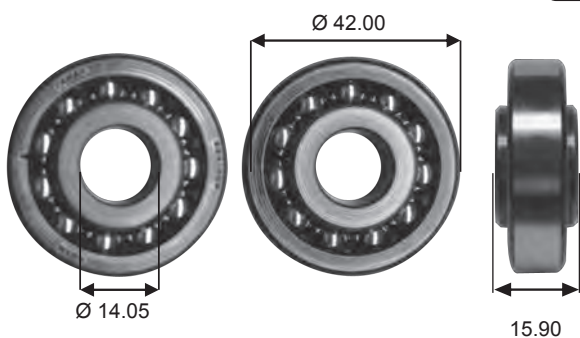

83A105BCS17

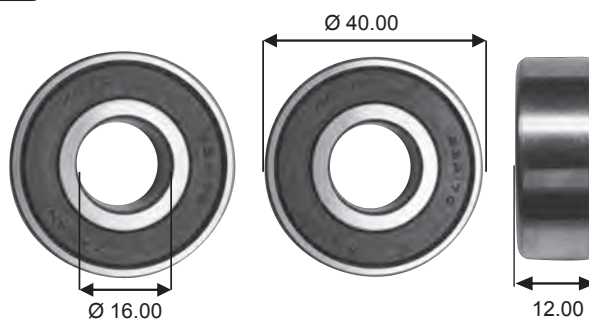

83A170C4

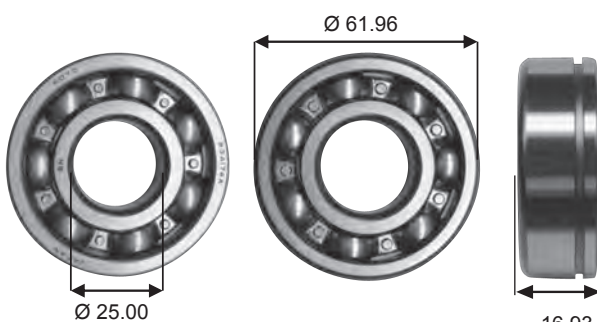

83A174ASH2C3

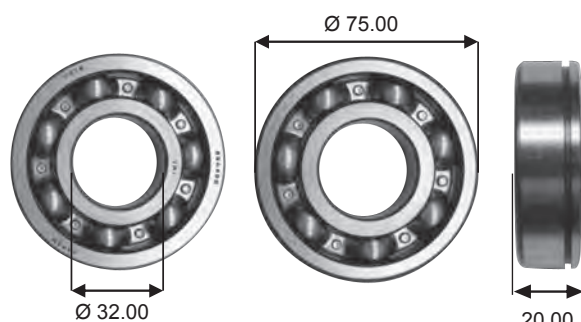

83A400C3

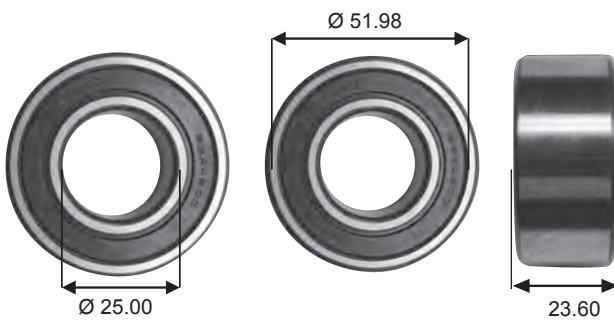

83A460CCS45

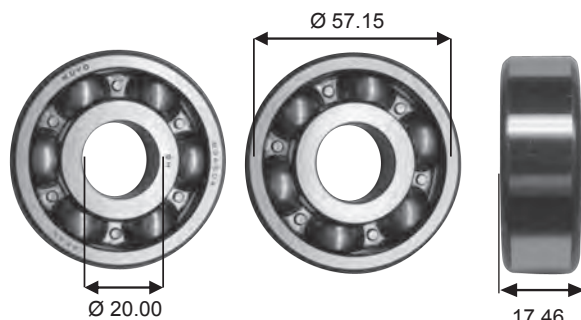

83A504SH2C3

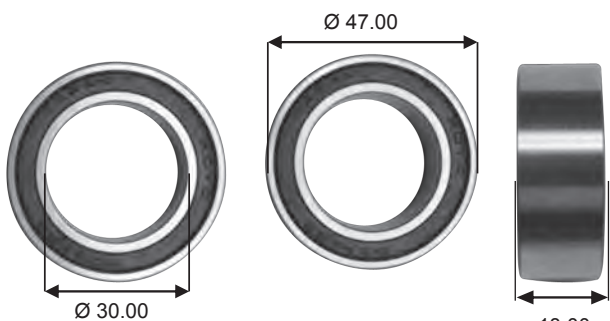

83A693CS30

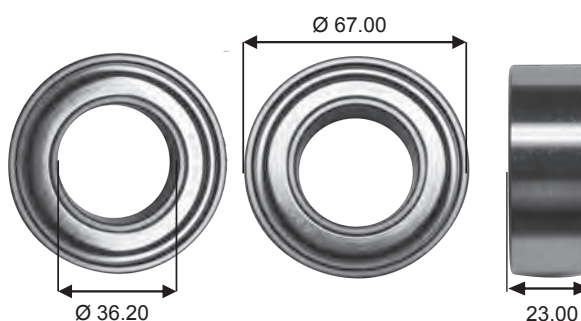

83A831GC5

▶ RODAMIENTOS AUTOMOTRICES

SERIE 83A000

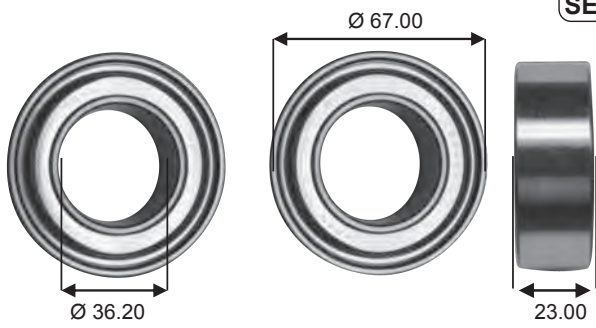

83A831GCS53

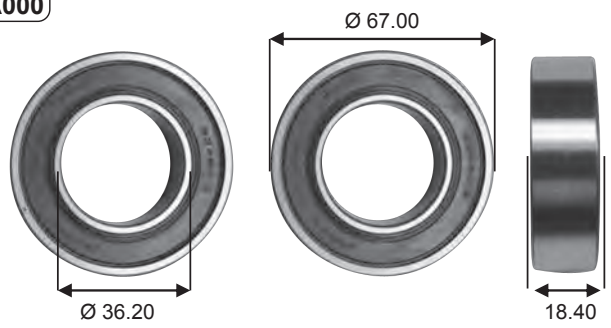

83A831SC5

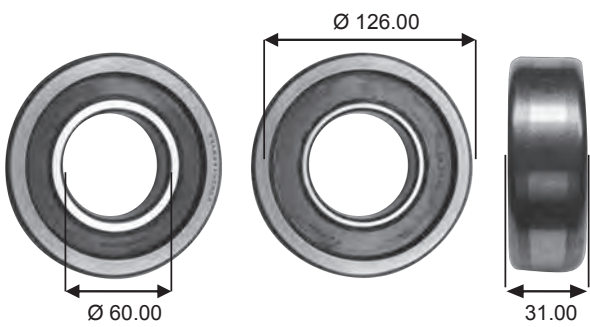

83A839AVCS62

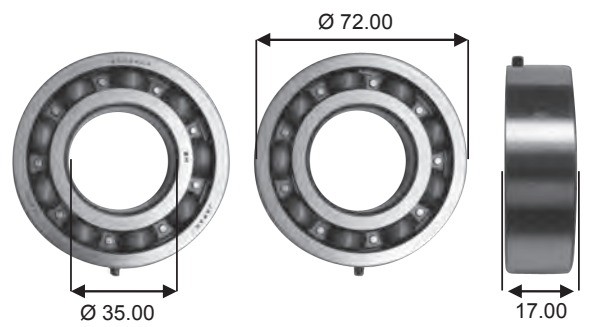

83A844ASH2 - 9TC4

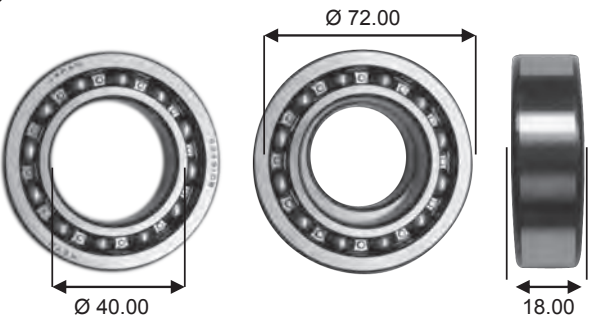

83A910BC3

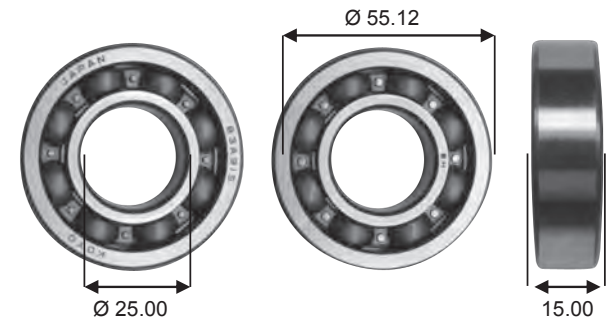

83A915SH2 - 9TC4

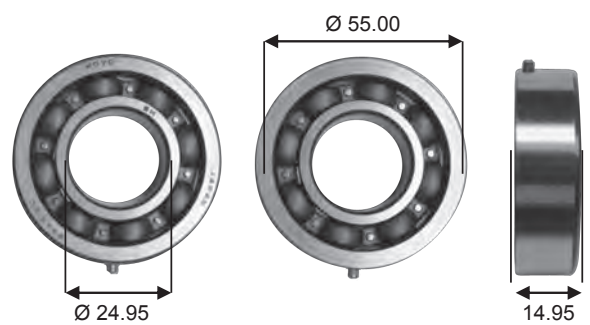

83A916CSH2 - 9TC4

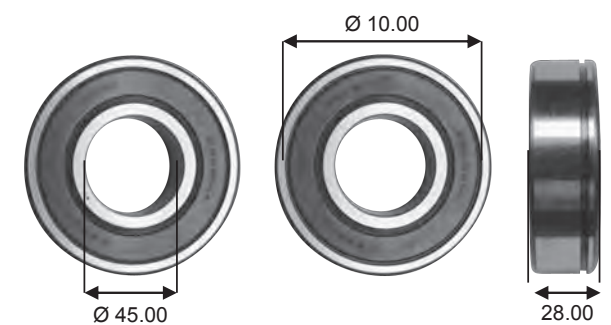

83A941ASH2C3

▶ RODAMIENTOS AUTOMOTRICES

SERIE 83A000

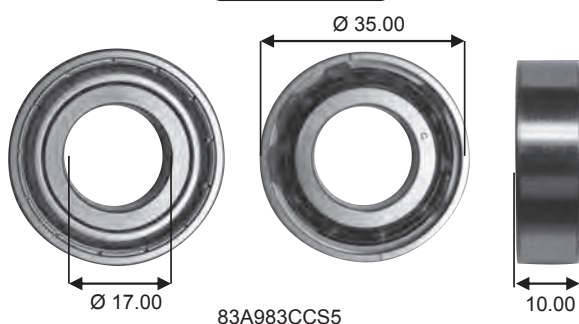

83A983CCS5

SERIE 83B000

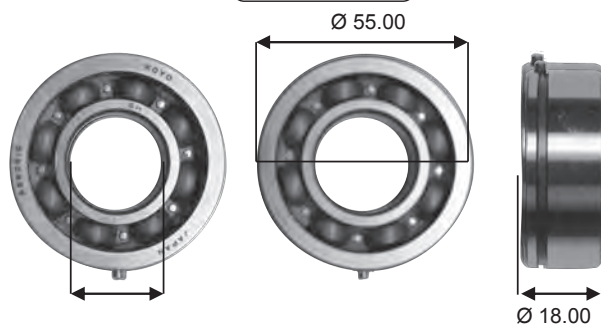

83B051DSH2 - 9TCS37

SERIE 83B000

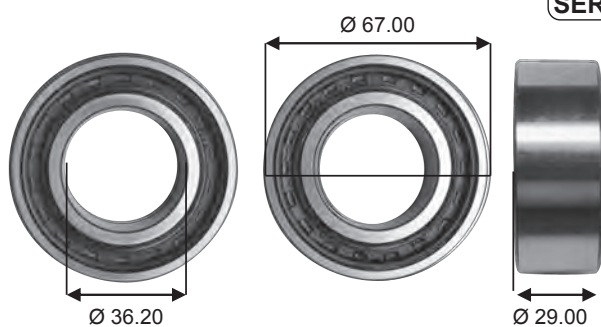

83B169ACS63

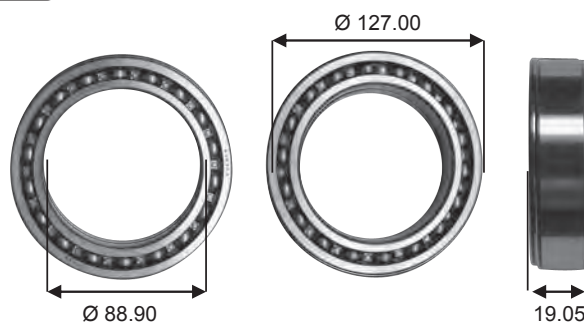

83B332

SERIE 83C000

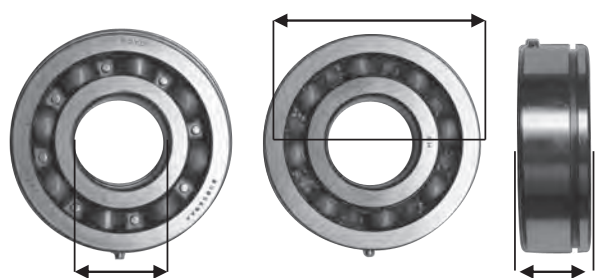

83B569AASH2 - 9TCS39

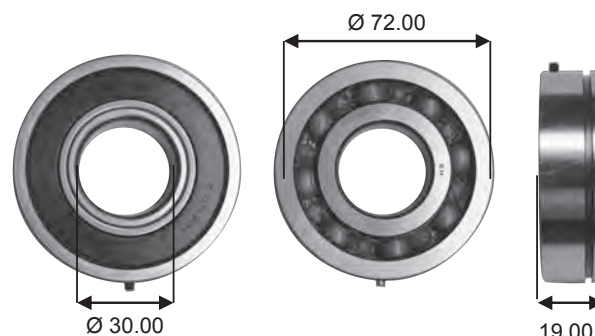

83C032SH2 - 9TCS37

SERIE 83C000

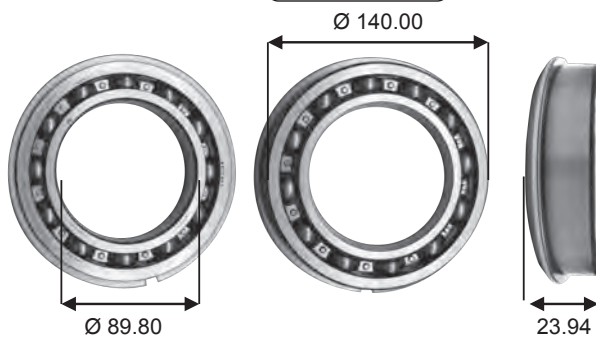

83C062DSH2

SERIE 88000

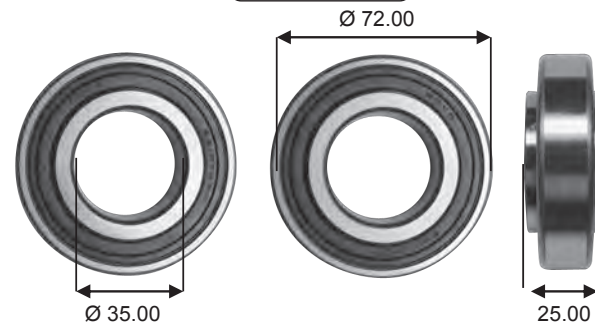

881072RR4

▶▶ RODAMIENTOS AUTOMOTRICES

